

The Intelligent Solution to Optimizing Internet Bandwidth

White Paper

Fourelle Systems, Inc.

3375 Scott Blvd.
Suite 102
Santa Clara, CA 95054
800.259.6973
www.fourelle.com

Overview

As the influence of the world wide web continues to increase, the requirement to connect to the Internet from more places and with more devices becomes more important. The adequate flow of data communication in systems with remote, wireless or bandwidth-constrained clients becomes a key factor in many of the emerging enterprise and business-to-business e-commerce applications. In a majority of today's distributed environments, adequate bandwidth is the most critical factor to success.

Fourelle Systems has pioneered and patented a bandwidth optimization technology that will enable any bandwidth-constrained network system to operate at higher performance levels. This technology is particularly applicable to 'closed network' Internet communications and dramatically improves performance and efficiency of e-mail, file transfers and web browsing. The result is performance gains of up to 85% for text-based transactions and up to 60% for graphics-based content.

At the heart of the Fourelle solution is proprietary data compression and transmission technology. Internet data is intelligently recognized and compressed depending on data type. This compressed data is then converted to a high-speed, bandwidth-efficient protocol and transmitted. At the receiving end of the transmission, the data is reconverted to its native format and made available to the client. Various data types are compressed differently for more efficient transmissions. Fourelle technology employs components at both the server and client locations creating a high-speed, closed network transmission.

The measurable benefits of using Fourelle technology in any bandwidth-constrained network include improved performance, faster access, increased capacity and throughput, reduced latency and lower operating and infrastructure costs. Less tangible, yet significant benefits include higher levels of user and customer satisfaction, better productivity and more efficient process flow.

Fourelle has implemented this bandwidth optimization technology in their Venturi™ product line. The Venturi Transport Protocol (VTP) maximizes performance for Internet data transmission of HTTP, POP3, FTP, NNTP and SMTP protocols. In addition, Venturi optionally includes a high-speed, multi-level cache.

Bandwidth-Constrained Connections

There's no question that the Internet is permeating all aspects of business and personal data communication. A simple summary of the new devices that are Internet-enabled includes everything from cell phones, to personal digital assistants, to wireless point of sale devices, to automated information loggers, etc. The Internet is reaching more remote locations and internetworking more diverse connections than ever before and at a staggering growth rate.

One common problem for many of these new connections is bandwidth--the virtual size of the pipe that carries information back and forth. Dialup lines, leased lines, wireless connections, satellite links, etc. in many situations suffer with poor performance and slow access due to bandwidth constraints. The amount of information that can be transmitted is restricted, interaction between client and server is limited, and overall performance is sub-optimal.

Increasing bandwidth in these environments is generally not an option. Radio frequencies, dialup lines, and remote connections are physically limited in the amount of data that can be transmitted across them. The solution to better performance and bandwidth optimization lies in making the transmission of data through the existing infrastructure more efficient.

The Solution

Fourelle Systems has developed patented technology that solves the bandwidth constraint problem for any type of Internet connection. This powerful technology is conceptually a simple answer to the problem of inadequate bandwidth--if the flow of data exceeds the bandwidth of the transmission pipe, compress the data and transmit it using a high speed protocol. Fourelle's solution controls the transmission from end to end to provide maximum efficiency and security. In addition, Fourelle's products accommodate multiple types of data and provide additional performance services such as caching.

At the heart of the Fourelle solution is an innovative collection of intelligence and compression algorithms that identify data by type, compress it, convert it to a high speed transmission protocol, transmit it, and then reconvert and decompress it at the receiving end.

Here's how the *process* works:

Intelligent Compression - Fourelle has implemented a collection of standard and proprietary algorithms that compress Internet data with greater efficiency than common compression techniques. Intelligent Compression determines the type of data being transmitted and applies the most appropriate compression method. Different data types include Web pages (HTTP), e-mail (SMTP/POP3), news (NNTP) and files (FTP).

Transmission - The compressed data is then converted to a high speed, UDP based transmission protocol called Venturi Transmission Protocol™ (VTP). Fourelle uses Intelligent Flow Control where a single request packet and a single response stream are transmitted across an optimized link. Using efficient retransmission methods and dynamically assigned timeout values, Fourelle adjusts the randomness of packet flow on the Internet and minimizes packet loss and redundant packet transmissions. (see fig a)

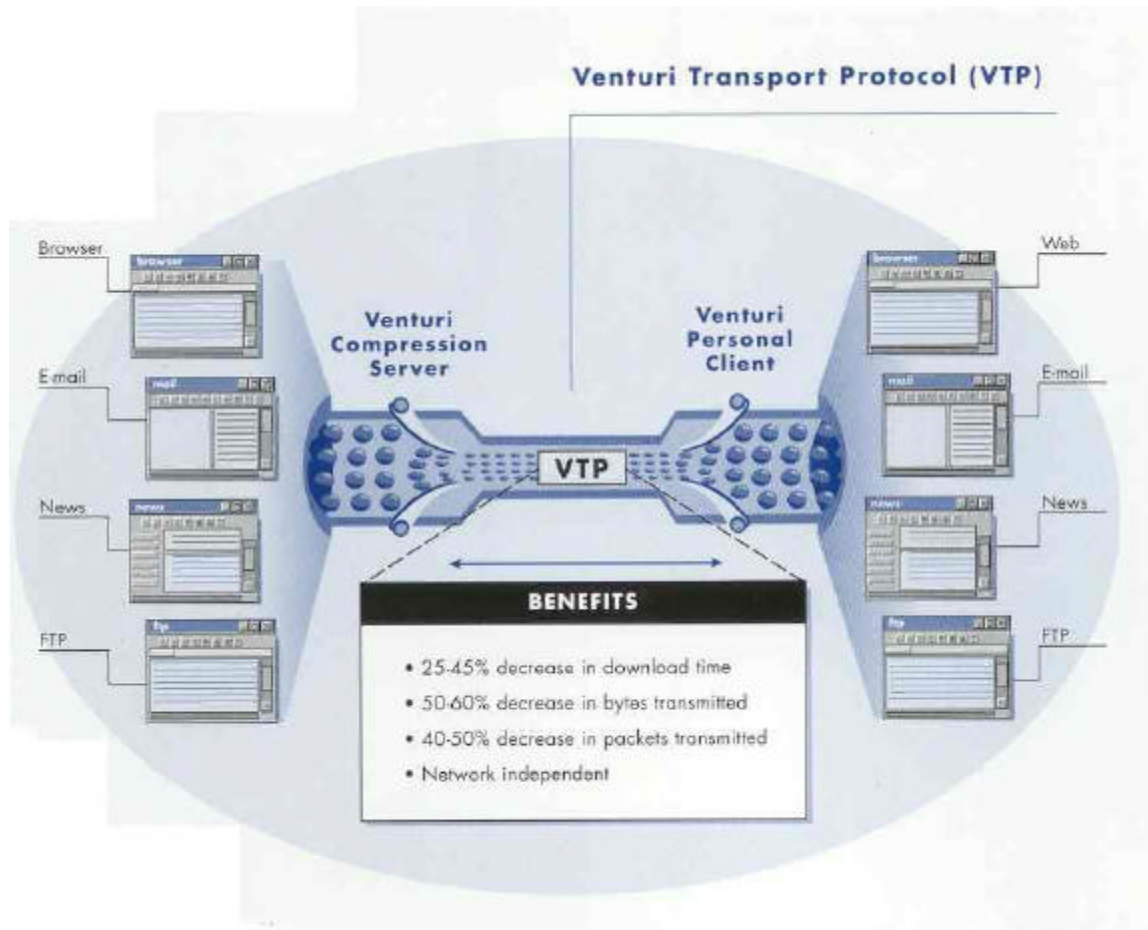

Here's the *platform architecture*:

Fourelle employs a dual-proxy, client/server architecture to enable high-speed transmission.

The client initiates a request for data and establishes a connection with the server. The server component receives the request, determines data type, compresses the data and initiates transmission to the client. On receiving the transmission, the client decompresses the data and converts it back to the original TCP/IP protocol with no need at either end to modify the data application.

Fourelle's Venturi™ Product

Fourelle has implemented this patented technology in their Venturi™ product line and provides for several possible configurations. This bandwidth optimization solution is viable for any type of constrained network including dialup Internet connections, wireless connections, virtual private networks (VPNs), satellite links, etc. Venturi components must be run at both sides of the bandwidth-constrained link.

The Venturi *server* is a proprietary hardware/software component located at the data source and consists of an embedded OS, two Pentium processors, 512MB RAM, 3.2GB drive cache and a network connection. The *client* is a software component and may be one of two general configurations: personal or workgroup. The *personal client* is a Java application that can be installed on any Windows or Macintosh workstation or in any Java runtime environment. (see fig b)

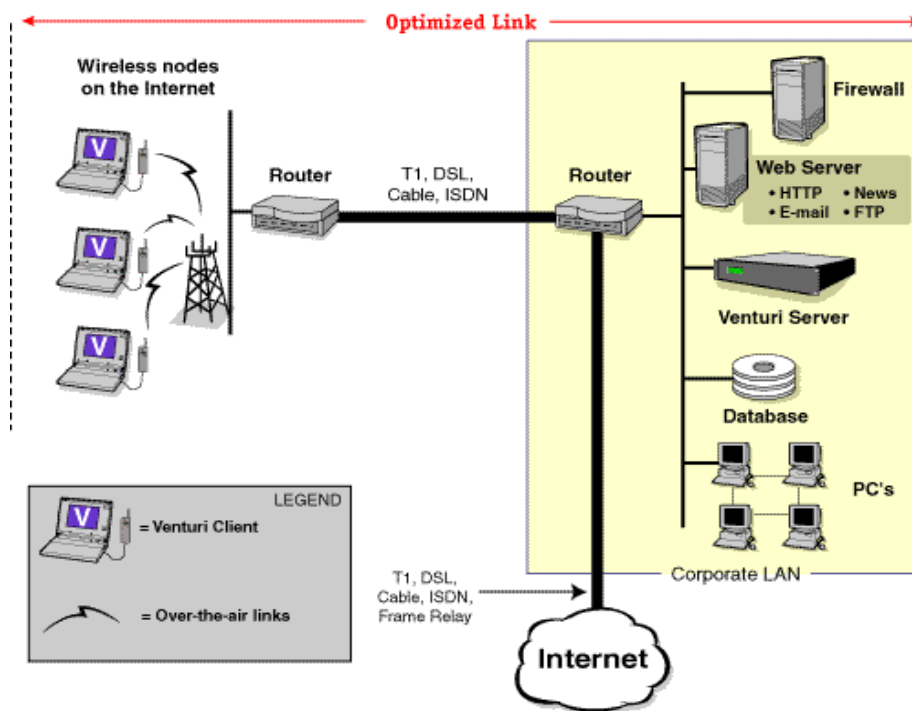

The workgroup configuration places a 'host PC' in the network which receives and converts the high-speed transmission and then channels it to individual workstations. (see fig c) Installation and configuration for server, personal client and workgroup client are simple with easy-to-use interfaces.

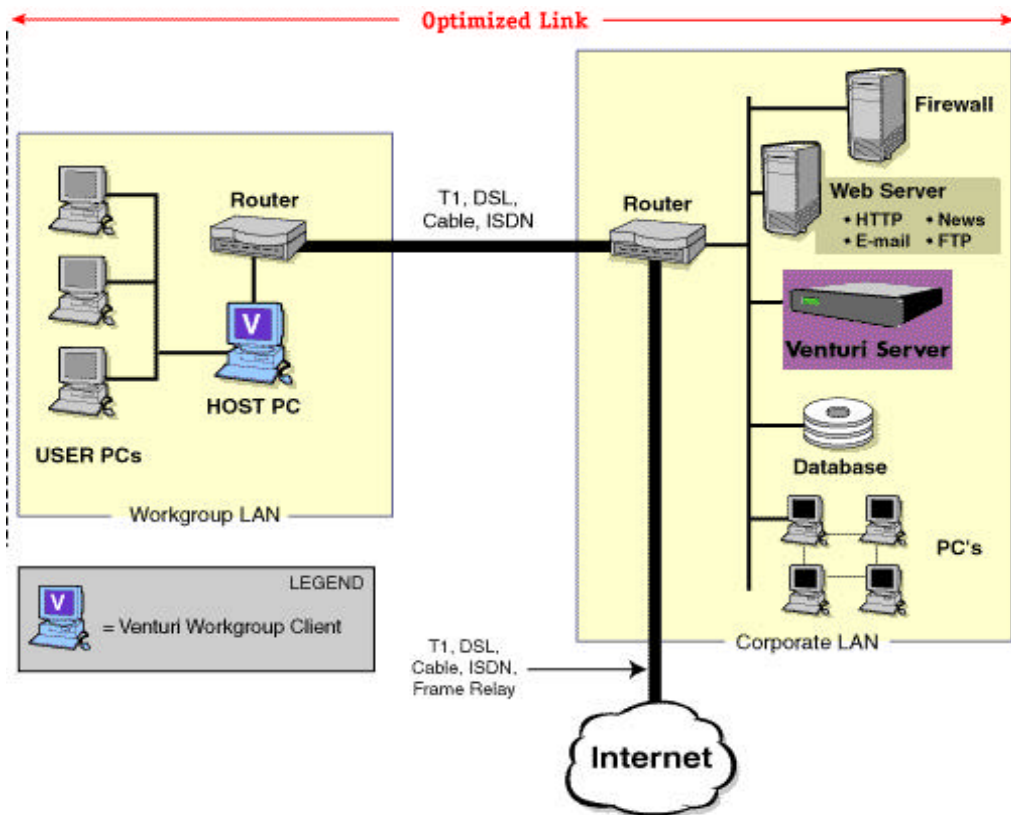

Fourelle's Venturi™ product also employs an optional integrated web cache to improve access speed and remove unnecessary network traffic from bandwidth-constrained network links. This allows data to be stored at a point on the network that is closer to the requestor, thus reducing traffic on the link behind the cache. Alternatively, Venture can be used with other web cache servers.

In a LAN or network configuration the Venturi server can be located anywhere on the network. The physical server footprint is a 2U-rack mount proprietary box running embedded Linux and plugs to any Ethernet network. The software client is runs in Win32 and Java 1.1 run time environments.

Uses for Fourelle Technology

Fourelle technology provides performance utility for multiple types of applications but it is particularly useful in networks where it is possible to have control of both the transmitting and receiving ends ('closed networks'). The following examples are areas where Fourelle technology excels at eliminating bandwidth constraints.

- **Wireless** - Internet to personal digital assistants, cell phones and other wireless devices. Wireless connections are typically bandwidth-constrained and using Fourelle technology increases performance, interactivity and total throughput.

- **Satellite** - Satellite connections are often used for connection in remote areas or for dissemination to geographically dispersed sites. Again, Fourelle technology increases performance produces acceptable connectivity over unconventional links.
- **Cable** - Fourelle can be implemented at a cable head and at a settop box to provide better performance for cable network applications.
- **Branch Offices** - For individual and group remote connections, Fourelle technology eliminates performance bottlenecks. Dialup, leased line and even T1 lines can be more fully utilized for higher throughput and better performance. Using a host PC, entire branch networks can have better connection performance.
- **VPN** - The Fourelle solution can make an existing Virtual Private Network more efficient without the need for additional network infrastructure.
- **Dynamic Data** - Fourelle technology is particularly suited to environments with dynamic or changing data. It's more than just a caching solution for static pages and has the ability to quickly deliver updates, changes or new query results.
- **Any more????**

Benefits

Using either Fourelle technology or Fourelle's Venturi™ product provides a number of benefits and advantages for businesses, organizations, Internet service providers (ISPs) and application service providers (ASPs) looking to increase performance. The benefits are summarized as follows:

- **Better Performance** - Web browsing, e-mail, file transfers, newsgroups and other applications all achieve higher levels of performance using Fourelle technology. Compression can result in an 85% reduction rate for transmitted data. On average, Venturi compresses text at 7:1, e-mail at 4:1 and 2:1 for Web browsing. Fourelle customers such as Porsche, Verizon, Bell Mobility and others experience performance percentage gains of up to 400%.
- **Faster Access** - Remote users, field employees, branch offices, wireless clients--all have faster access which leads to higher productivity, smoother interaction, reduced latency and increased utility.
- **Increased Capacity** - Compressing data and using a high speed protocol effectively makes it possible for existing infrastructures to increase capacity. The same system can now support more users/more throughput.
- **Higher Satisfaction** - Users, customers, managers and partners at a minimum appreciate speed and are often annoyed or impatient with poor performance. Good connections help to foster loyalty and customer satisfaction.
- **Lower Costs** - Increased capacity, higher throughput, better customer satisfaction--all contribute to lower costs and higher revenues. Significant cost savings can be realized by utilizing existing infrastructure. The ability to

have premium performing wireless applications can be a strategic revenue advantage.

Summary

With its unique combination of bandwidth optimizing technologies, Fourelle provides a broad-based solution that offers a cost-effective increase in capacity and performance improvement. Managers of corporate enterprise and public IP networks will find Fourelle highly effective, easy to use and simple to maintain while realizing a rapid return on investment. In wireless, satellite, remote access, Virtual Private Network (VPN), or consumer dial-up IP environments, Venturi provides a greater, more economical utilization of existing Internet infrastructure without the additional recurring costs of purchasing bandwidth.